

3,000 POUND CAPACITY AUTO BODY ROTISSERIE UNIT

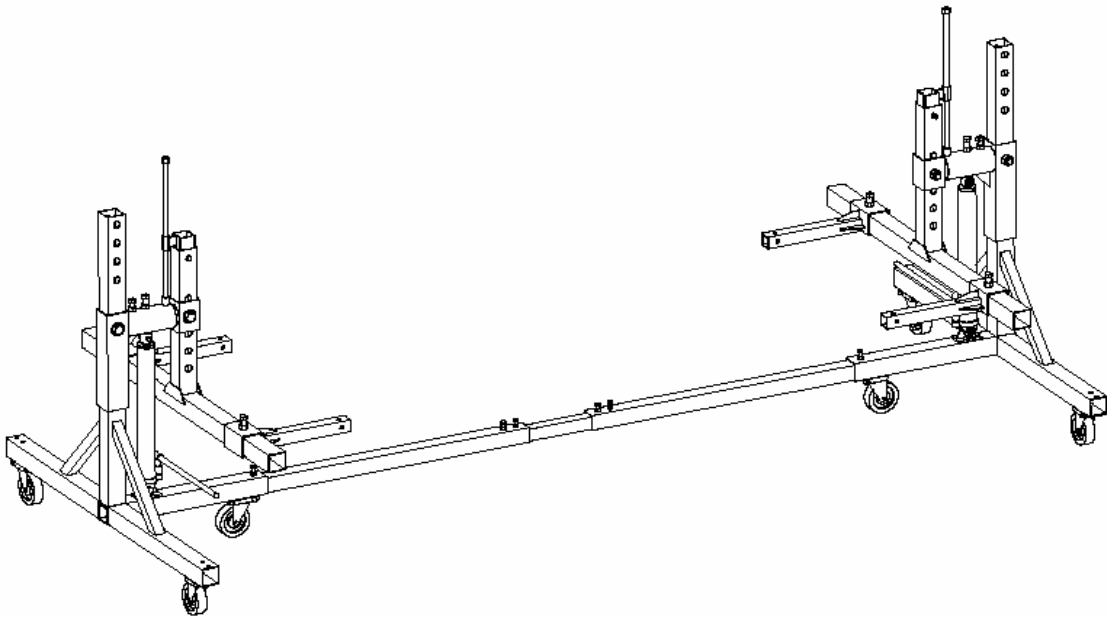

INSTALLATION / OWNERS MANUAL

TABLE OF CONTENTS

- **IMPORTANT INFORMATION** pg 2
- **OWNER / EMPLOYER RESPONSIBILITIES**..... pg 3
- **SAFETY PROCEDURES** pg 3
- **GENERAL INFORMATION and FEATURES** pg 3
- **INSTALLATION / OPERATION PROCEDURE** pg 4
- **VEHICLE BALANCING OPERATION** pg 7
(Adjusting center of gravity of vehicle)
- **ILLUSTRATED PARTS BREAKDOWN**..... pg 9
- **PARTS LIST**..... pg 10

IMPORTANT INFORMATION

Any freight damage must be noted on the freight bill before signing and reported to the freight carrier with a freight claim established. Identify the components and check for shortages. If shortages are discovered, please contact the Distributor / Sales Rep. in your area for service.

Make sure you have extra help or heavy duty lifting equipment when unloading and assembling the Rotisserie unit.

Please read the safety procedures and operating instructions in this manual before operating Rotisserie unit. Keep this manual near Rotisserie unit at all times. Make sure all operators read this manual.

This is an Auto Body Rotisserie unit installation/operation manual and no attempt is made or implied herein to instruct the user in specific methods particular to an individual application. Rather, the contents of this manual are intended as a basis for operation and maintenance of the Rotisserie unit as it stands alone or as it is intended and anticipated to be used in conjunction with other equipment.

Proper application of the equipment described herein is limited to the parameters detailed in the specifications and the uses set forth in the descriptive passages. Any other proposed application of this equipment should be documented and submitted in writing to the factory for examination. The user assumes full responsibility for any equipment damage, personal injury, or alteration of the equipment described in this manual or any subsequent damages.

OWNER / EMPLOYER RESPONSIBILITIES

The Owner / Employer:

- Shall establish procedures to periodically maintain, inspect, and care for the Rotisserie unit in accordance with the manufactures recommended procedures to ensure its continued safe operations.
- Shall provide necessary lockout / tag outs of energy sources per ANSI Z244.1 –1982 before beginning any lift repairs.
- Shall not modify the Rotisserie unit in any manner without prior written consent of the manufacturer.
- Shall insure that lift operators are instructed in the proper and safe use and operation of the Rotisserie unit using the manufacturer's instructions.

SAFETY PROCEDURES

Total Rotisserie unit capacity is **3,000lbs @ 1,500 lbs per end**. Do not exceed maximum weight capacity.

Prior to working with Rotisserie unit, walk around and check for any objects that might interfere with the operation of unit such as: tools, air hoses, shop equipment, etc.

These are generic instructions, please keep in mind there are different ways to hook up the same vehicle. Make sure to properly secure and balance vehicles center of gravity before using the rotisserie.

NOTE: There are no set rules when hooking up a vehicle – just make sure there is a strong enough mounting point.

GENERAL INFORMATION and FEATURES

The Auto Body Rotisserie is a restoration rotisserie that is designed to make restoring any vehicle a simple and easy task. The Auto Body Rotisserie uses heavy duty ram jacks at each end with a slow release mechanism for safe load lowering and also incorporates an extra long power stroke with hydraulic bypass valves preventing the cylinders from over traveling.

The Auto Body Rotisserie will also lower down to most bumper heights allowing capability to lift the body of the vehicle to any height.

Whether you're an owner of a large restoration shop or simply a home hobbyist, the Auto Body Rotisserie provides an efficient and affordable way for anyone to restore old classic vehicles.

INSTALLATION / OPERATION PROCEDURE

1. Install the 6 Caster Wheels to the bottom of each Rack Leg, Fig. 1. **NOTE: Do not over tighten bolts.** Install Upright to legs as shown, Fig. 1. You will install 7 bolts, flatwashers, lockwashers and nuts.

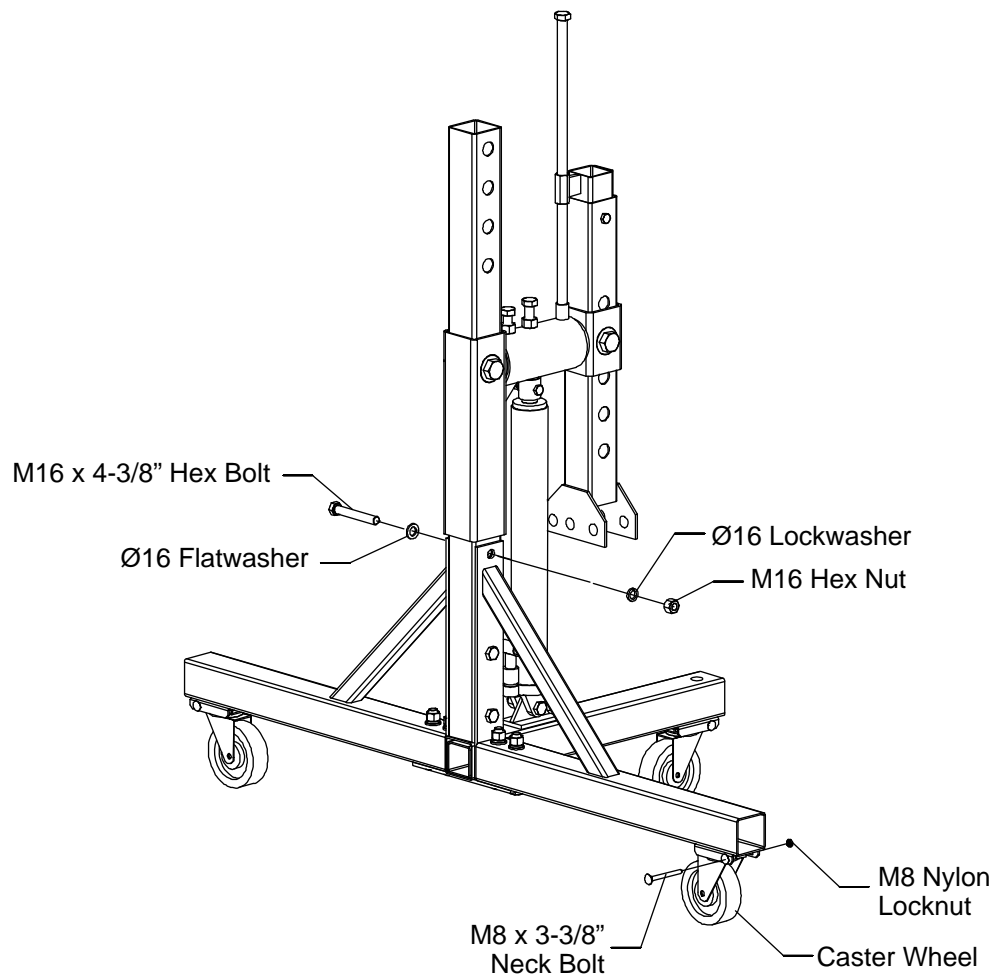

FIG. 1

2. Install Horizontal Swing Arms as shown, Fig. 2.

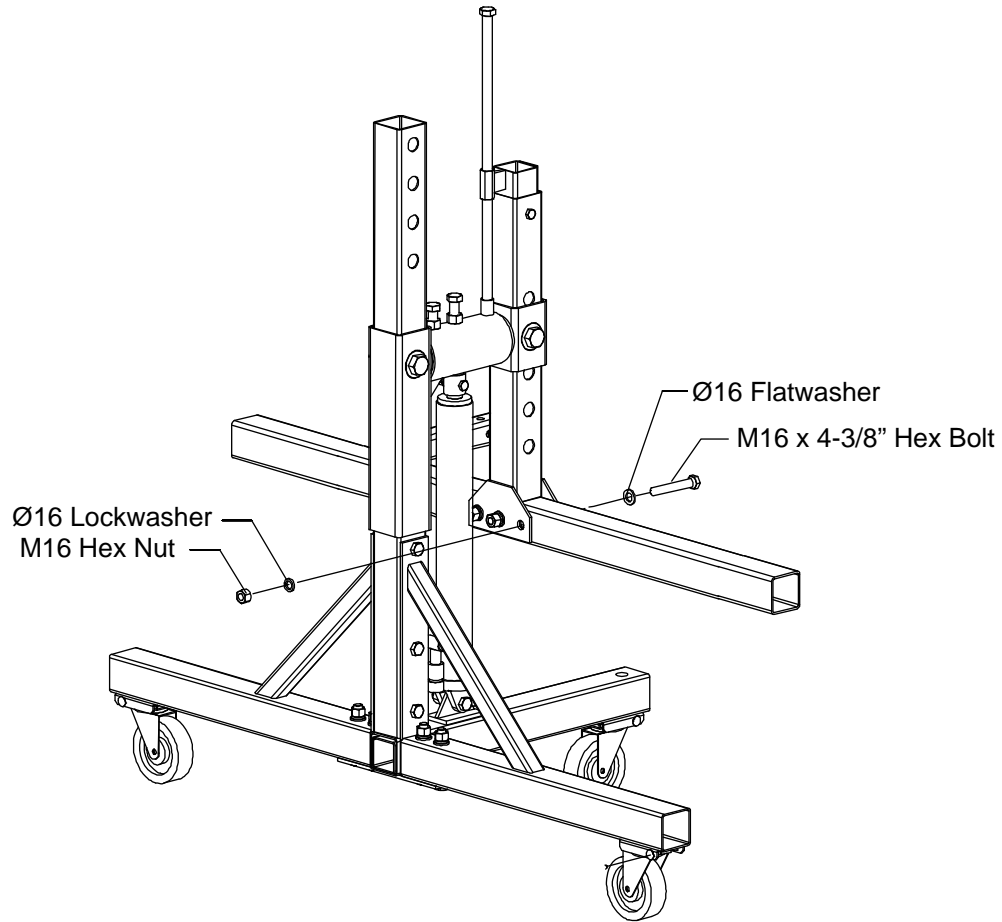

FIG. 2

3. Install Adapter Arms, Fig. 3.

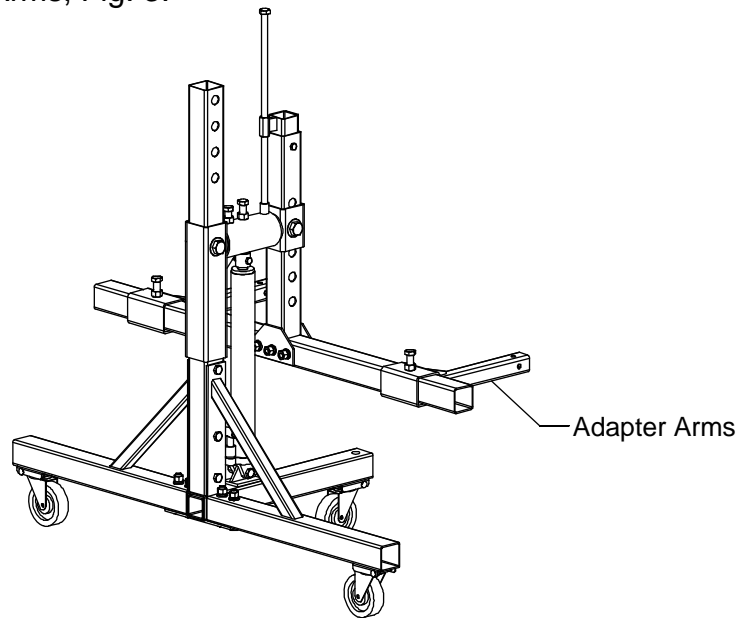

FIG. 3

4. Apply good grade lithium shop grease to all sliding parts. This will provide for smooth and easier operation.
5. Check your mounting point for your particular vehicle. This can be different, depending on the make/model of your vehicle.
6. With the vehicle on Jack Stands, center the Auto Body Rotisserie bases to the front and rear of vehicle. **NOTE: Sometimes vehicles are heavier on one side and will need to be offset to that side.**
7. Mount the Auto Body Rotisserie Adapter Arms to the vehicle.
8. Place the Connecting Tubes in the center of the Rotisserie unit end pieces and tighten bolts, Fig. 4. **NOTE: Leave one end loose until ready to lift vehicle.**

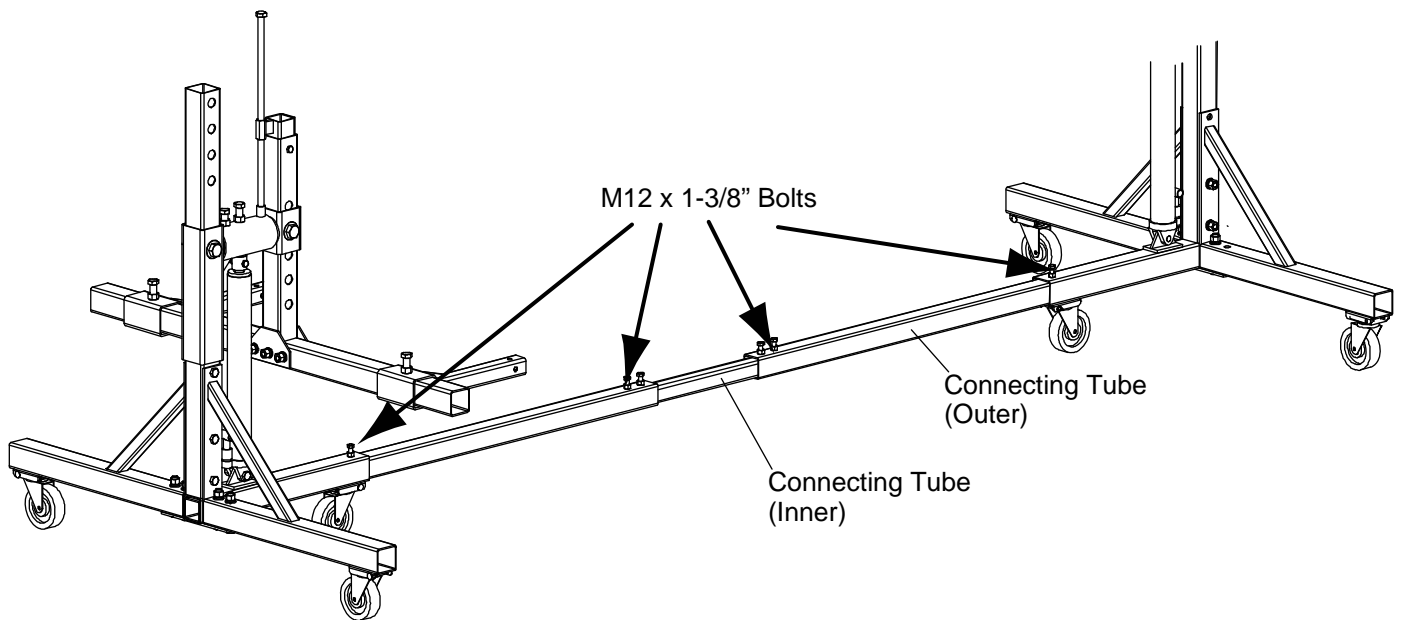

FIG. 4

9. Check all mounting bolts to insure they are tightened properly and there is enough distance between the vehicle and Auto Body Rotisserie unit.
10. Make sure that Rotisserie bases are parallel to each other. Now you can fully tighten the Connecting Tubes.
11. Now begin lifting the vehicle up with the hydraulic cylinders. Lift just high enough to remove Jack Stands.
12. **NOTE: The vehicle is not centered and balanced and will not spin yet. It will just swing like a clock pendulum.**

See next section for proper “center of gravity” and balancing procedure

VEHICLE BALANCING OPERATION

(Adjusting the “Center of Gravity” of the Vehicle)

13. **CAUTION:** This is the most dangerous time during the use of the Auto Body Rotisserie unit. We have incorporated safety features that prohibit you from turning the Rotisserie unit while adjusting. This also prevents the unit from slipping while adjusting.
14. Always start with the Swing arms (upside down “T”) as low as it can be. **NOTE:** This will make the vehicle bottom heavy to help prevent causing an accident or personal injury.
15. Align the Rotation Balancer so the Balance Bolt/Arm fits into the welded cup located on top of the Pivot Point Base, Fig. 5. **NOTE:** This is what prevents you from turning while adjusting.

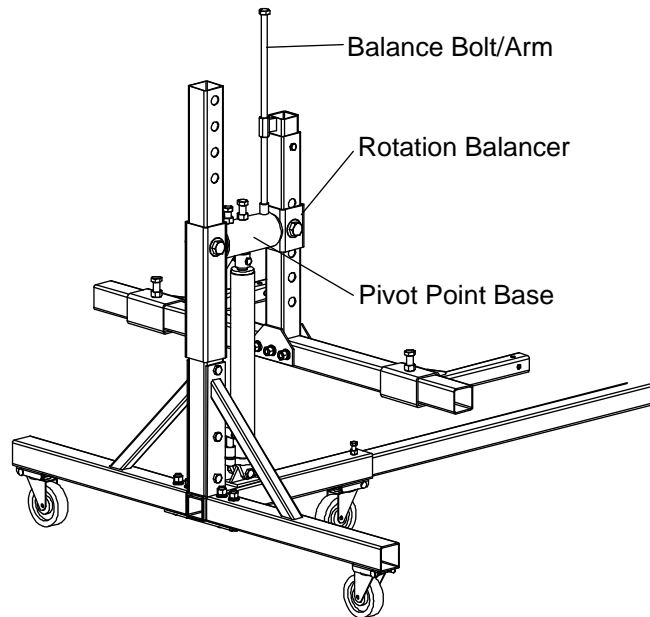

FIG. 5

16. Apply pressure with the Balancer so you can remove the Bolt, Washer and Nut that holds the swing arm in place, Fig. 6.

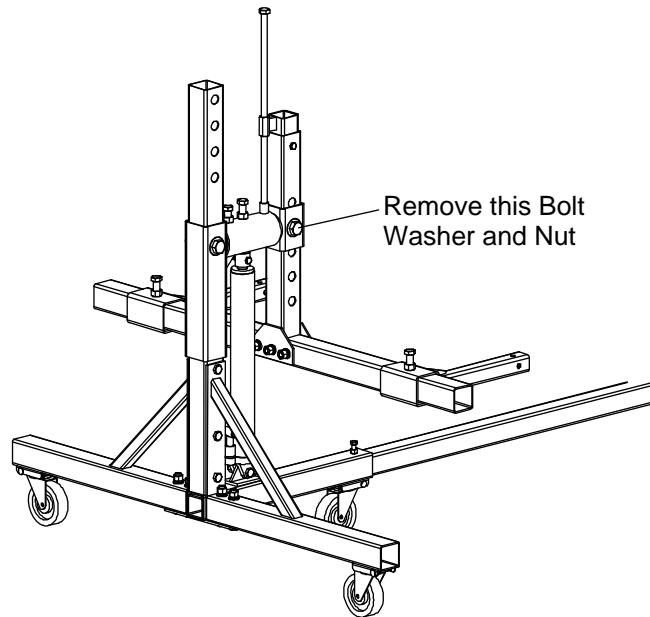

FIG. 6

17. Raise the Swing arm up using a socket or impact wrench, being sure to move each end up only one hole at a time. This is to prevent any binding.
18. Put the large Bolt, Washer and Nut in the next hole and tighten.
19. Back out the Balance Rod enough to swing the vehicle.
20. Test the balance by swinging the vehicle from side to side.
21. If the vehicle is still bottom heavy REPEAT FROM STEP #15 testing the balance in each hole. **NOTE: As long as you don't jump over holes the difference from one hole to the next is never so great as to become uncontrollable.**

Hydraulic Fluid

If hydraulic fluid needs to be added to hydraulic cylinders, please use:

ISO 32 Light Hydraulic Oil

ILLUSTRATED PARTS BREAKDOWN
R3000G
Auto Body Rotisserie Unit

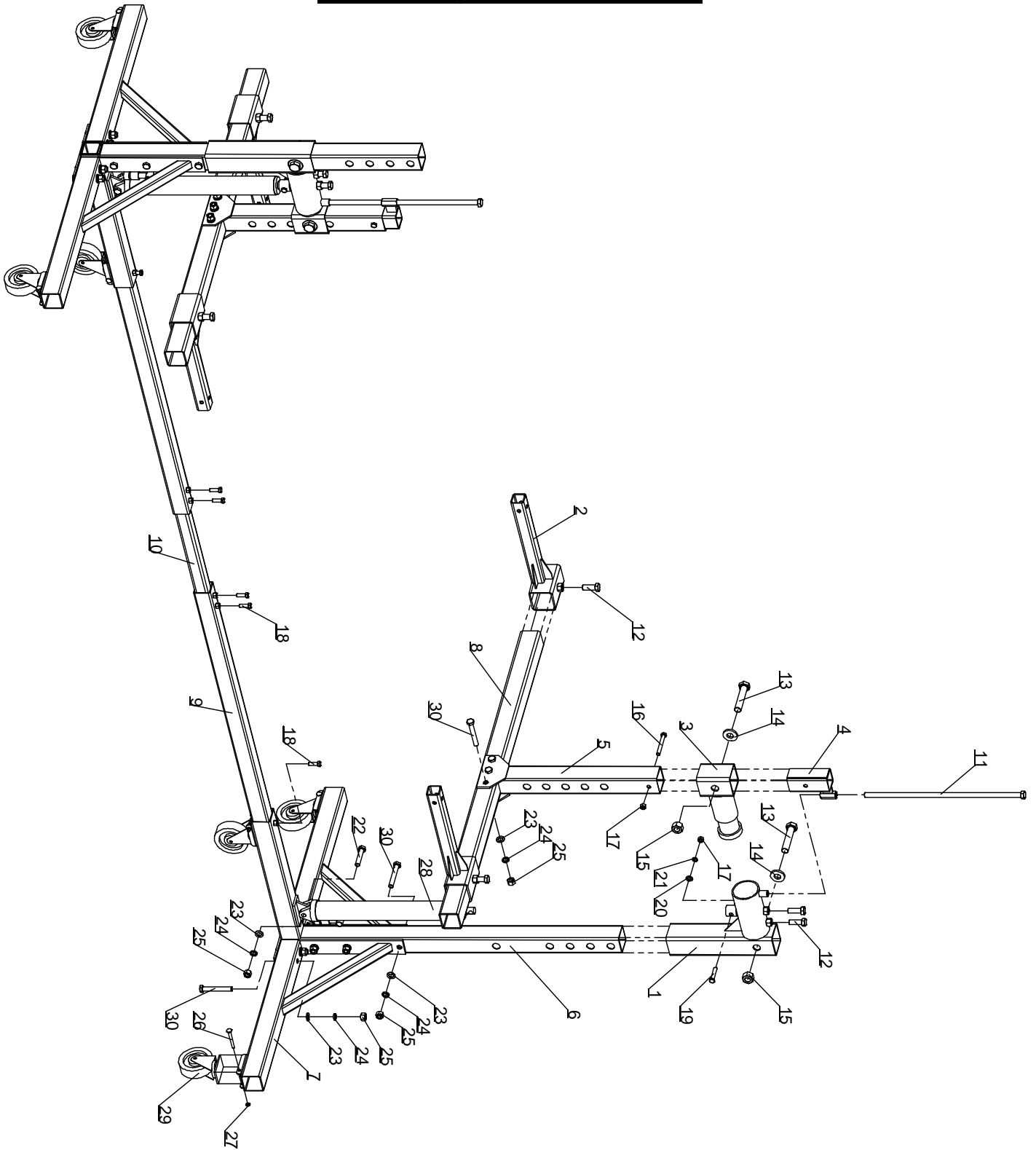

Rotisserie Parts Breakdown

1	R3000-1000	Pivot Point Base	2
2	R3000-2000	Adapter Arms	4
3	R3000-3000	Pivot Attachment	2
4	R3000-4000	Rotation Balancer	2
5	R3000-5000G	Swing Arm Upright	2
6	R3000-6000A	Rack Weld Upright	2
7	R3000-6000B	Rack Legs	4
8	R3000-5001G	Swing Arm Horizontal	2
9	R3000-0001	Connecting Tube	2
10	R3000-0003	Connecting Tube	1
11	B11-18x600	M18x600 (23-5/8" long) Bolt	2
12	B11-18x50	M18x50 (2" long) Bolt	8
13	B11-24x120	M24x120 (4-3/4" long) Bolt	4
14	R3000-0002	Washer	4
15	B31-24	M24 Hex Nut	4
16	B11-12x100	M12x100 (3-15/16" long) Bolt	2
17	B31-12	M12 Hex Nut	4
18	B11-12x35	M12x35 (1-3/8" long) Bolt	6
19	B11-12x60	M12x60 (2-3/8" long) Bolt	2
20	B41-12	Ø12 Flat Washer	2
21	B40-12	Ø12 Lock Washer	2
22	B11-16x80	M16x80 (3-1/8" long) Bolt	2
23	B41-16	Ø16 Flat Washer	22
24	B40-16	Ø16 Lock Washer	22
25	B31-16	M16 Hex Nut	22
26	B16-8x85	M8x85 (3-3/8" long) Neck Bolt	6
27	B33-8	M8 Nylon Lock Nut	6
28	R3000-9100	Cylinder	2
29	B80-5x1.5	5"x1.5" Casters	6
30	B11-16x110	M16x110 (4-3/8" long) Bolt	20

Optional Accessory Parts Available For Rotisserie Unit

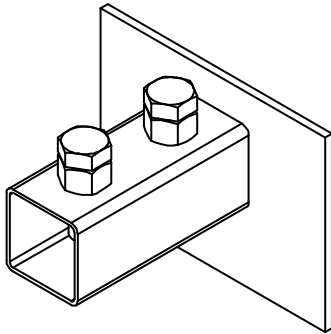

Uni-Body Bracket
Part A3000-A1

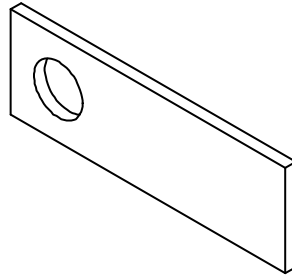

Mounting Bracket
Part A3000-A3

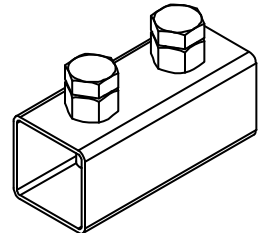

Leaf Spring Bracket
Part A3000-A4

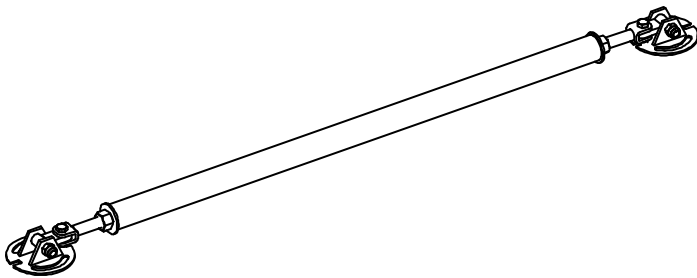

Universal Door Bar
Part A3000-A5

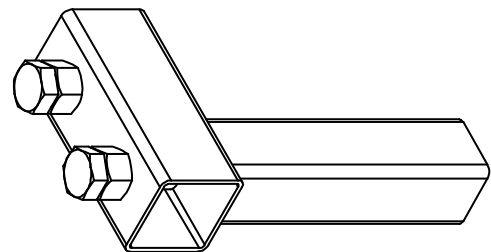

Valance Bracket
Part A3000-A2

